

HARTLEPOOL BOROUGH COUNCIL SKIP LICENCE POLICY

October 2012

Before reading these pages please note that requests to place a skip on the Public Highway will not be accepted from the person(s) hiring the skip. The request will be made by the Authorised Skip Hire Contractors.

We as the Highway Authority for Hartlepool authorise skips to be placed on the Public Highway or other Council lands, at certain locations, under Section 139 of the Highways Act 1980. The following Policy details the criteria that we apply to this function.

1. Skips **shall not** be deposited on any part of the highway or public right of way or other Council lands unless Hartlepool Borough Council, being the Highway Authority for the area, has issued a skip licence.
2. If possible **three working days** notice should be given prior to placement of the skip on a highway.
3. Skip licenses will only be issued to the owner/operator of the skip to be deposited.
4. All skip owners must be registered with Hartlepool Borough Council and, in this respect, must adhere to the rules and regulations specified in this policy.
5. Skip companies must, on an annual basis; provide copies to the Council of their public liability insurance being to a minimum value of £2,000,000.
6. Licenses will be issued for a period of **14 Days** and a charge of **£12.50** per skip will apply. Any skip required for a period longer than 14 days will require a new licence and a further charge of **£12.50 (per 14 days)** will be payable.
7. Skips placed on the highway or Council land without a valid licence will be subject to a retrospective licence fee, retrospective licence fees will be at **£25.00**
(see additional note: *Retrospective Licence Issue*)
8. Skips located on the highway or Council land must be positioned on the carriageway, **not** on the footpath or grass verge areas unless with prior approval of the Council.

Cont.

9. Should the skip be positioned on any Council footway, footpath or verge the skip company will be liable for any and all costs of repair for any damage caused by their actions.
10. Skips shall not be placed on a highway or Council lands contrary to a traffic regulation order restricting the parking of vehicles on that section of highway.
11. Where a skip is to be located in an area subject to a residents parking-bay regime the skip shall be positioned so as to be directly outside the property of the resident hiring the skip.
12. If a skip is to be positioned in a back street the skip must be removed on the evening prior to refuse collection day for that street. Details will be included on the licence.
13. The skip shall be positioned so that its longer side(s) is parallel to the edge of the carriageway and as near to the edge of the carriageway as is reasonably practicable so that it does not impede the surface water drainage of the highway nor obstruct access to any manhole or to any statutory undertaker or Hartlepool Borough Council apparatus.
14. When more than one skip is on the highway at any one time the skips shall be positioned as closely as possible to each other.
15. Skips shall be positioned so as to not obstruct access to any premises, unless the consent of the occupier of those premises has been obtained.
16. Each skip shall not exceed 8 cubic yards in capacity. Skips larger than 8 cubic yards must have prior approval from the H.B.C. Licensing Officer
17. Roll-on/Roll-off skips (20 cubic yd +) are not allowed on the highway without a written application (from the applicant) and written permission from the Council, if permission is granted the skip must not be left out overnight.
18. Each skip, or group of skips, shall, while on the highway or Council land, be marked (guarded) and lit in accordance with the:

‘Department of Transport’s Builders’ Skips (Markings) Regulation 1984 (copy of ‘Markings’ document attached)

19. No skip, when standing on the highway or Council land, shall contain any inflammable, explosive, noxious or otherwise dangerous material which is likely to putrefy or which otherwise is, or is likely to become, a nuisance to users of the highway.

20. No skip shall be used in such a way that any of its contents can fall onto the highway, project over the adjoining footway or that there is an escape of dust from the contents of the skip when standing on the highway.
21. Each skip shall be removed for emptying as soon as practicable and in all cases not later than **one working day** after it has been filled.
22. All materials placed in each skip shall be appropriately disposed of and the highway where the skip(s) have been deposited shall be left in a clean and tidy condition on the expiration of this permission.
23. If a skip is deposited on the public highway for which a licence has not been applied for the owner of said skip shall be instructed to remove the skip immediately and apply for a retrospective skip license (retrospective skip licenses will be at a fee of **£25.00**)
24. A skip placed on the highway without a valid local authority licence is illegal. Skip owners will be notified of any unlicensed skip by way of a 'Formal Warning' notice and a retrospective Licence will need to be applied for. Formal Warning notices will be forwarded to H.B.C. Enforcement Section (this may result in legal action being taken against the skip owner/operative).
25. License cancellation: the license fee is to cover the cost of processing a license. Fees will only be cancelled if a license has not been processed, or if the cancellation is within two hours of submitting the application.
26. A register will be maintained by Hartlepool Borough Council recording all skip placements and licence issue. Skip licence invoices will be issued on a monthly basis for licences issued during that period.
27. Private Land – If a skip is to be placed on non-Council land or private land a HBC skips licence is not necessary. It is however the duty of skip operators to ensure that the placement is on private land only, any unlicensed skip identified on the council highway will automatically be issued with a retrospective licence.

ALWAYS ENSURE UNLICENSED SKIPS ARE ON PRIVATE LAND

Additional Notes

Applying for a licence

Licences can be applied for using the following methods:

- **By fax:** – (01429) 523541
- **By Telephone:** – (01429) 284072 - followed by confirmation fax, email or on-line application
- **On-line** @
- **By Email** :- highwayslicensing@hartlepool.gov.uk

http://www.hartlepool.gov.uk/forms/form/126/skip_licence_application

Licence applications can be processed Monday to Friday 8.00am – 4.30pm

Licence application – Weekend & Holiday periods

Licences must be applied for prior to placing a skip on the highway. If a skip is deposited on the highway during a weekend or Bank holiday period a license application can still be applied for by fax or on-line during these periods. Fax and on-line applications, during out-of-hour periods, will have a log date and time, this will be proof of application. A licence will be issued by the Council for applications requested outside of normal office hours at the first opportunity.

Retrospective Licence Issue

Facilities are in place for receiving skip licence applications during weekend and Bank holiday periods as detailed above. Any skip placed on the highway without a valid licence or proof (via fax, email or on-line method) of application will be issued a retrospective licence.

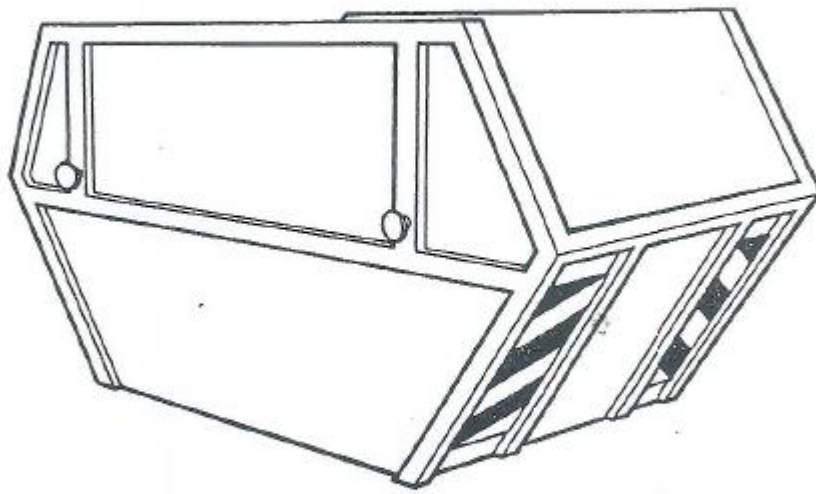

Builders Skips Markings

Department of Transport
2 Marsham Street
LONDON SW1P 3EB

REFLECTIVE MARKINGS ON BUILDERS' SKIPS

Introduction

Following reports of a number of accidents where motorists and motor cyclists had collided with unlit builders' skips sustaining serious injury, the Government has decided to introduce the Builders' Skips (Markings) Regulations 1984..

With effect from 1 January 1986 the Regulations require all builders' skips deposited in the roadway to be fitted with RED and YELLOW fluorescent/reflective markings. The only exception is where the skip is completely off the road on a footpath or verge (as is the case with bottlebank containers).

Even with these markings a skip must also be properly lit at night and meet any other conditions imposed by the local highway authority when granting permission for the skip to be placed in the road or on the highway.

Skips come in various shapes and sizes. This leaflet attempts to show how the marking plates can be used to best effect on different types of skips.

Types of marking

The markings on the skips are the same design and construction as the vertical rear markings on heavy goods vehicles. They must conform to, and be marked with the British Standards Number BS AU 152 : 1970.

Painted markings are illegal. Vertical markings only are to be fitted.

The marking plates should be a full 700mm high and 140mm wide. If a skip with lower ends is being used the plates may also be lower, with the minimum legal height of any plate being 350mm, but with a corresponding extra width to give the same visibility.

The area of any plate should never be less than 980 square centimetres.

Method of Attachment

The fluorescent/reflective materials should not be attached directly onto the end of the skip as they will be difficult to replace when worn. It is better to attach lorry type rear marker plates onto the skip.

If a skip is used regularly a permanent plate fixture using rivets is recommended. If the markings are only occasionally needed then a temporary fixing with screws can be used.

But for either permanent or occasional use the markings must always be fitted to the skip in a VERTICAL position.

Where to fit the plates

Height: The plate(s) should be attached as near to the top rim of the skip as possible provided that:

- * the whole of the plate can be clearly seen by all other drivers and is not even partially obscured by an angled rim or a strengthening bar of the skip.
(See figure 1a.)
- * the top of the plate is no more than 1.5 metres from the ground once the skip is in position.
- * the plate is not fitted to a lid or cover.

Spacing : The plates should be as near to the skip's side edge as possible provided that:

- * they do not protrude beyond the side of the skip
- * they are the same distance as each other from the sides of the skip.
- * they are not mounted on any ribs or strengthening bars which are narrower than the plates. The skip's recessed surface which is surrounded by the skip's ribs and strengthening bars is the ideal place for the plates (see fig. 1).
- * they are not fitted to a door unless there is no alternative ie where a door forms the full width of the end of some skips (see fig. 3 and 7).

If the plates must be fitted to doors, the doors must be kept closed unless loading is taking place.

Skips placed sideways

If a skip is positioned sideways in the road the markings must be fixed onto the sides which then form the ends of the skip facing oncoming traffic (see fig. 8).

Clarity of the markings

The markings must be clean and clearly visible at all times. The new law puts the onus on skip operators to ensure the markings are kept in good repair and are replaced when damaged or badly worn.

The attached illustrations show the recommended fixing positions of markings to various types of skips. If you have difficulty in deciding how to fix markings to a skip not shown here, please write to the address below enclosing a photograph or drawing of the skip in question.

Also reproduced at the end of this leaflet are extracts from the Regulations relating to the design and fitting of the markings.

Department of Transport
Traffic Signs Branch
Room S16/13
2 Marsham Street
London SW1P 3EB

January 1985

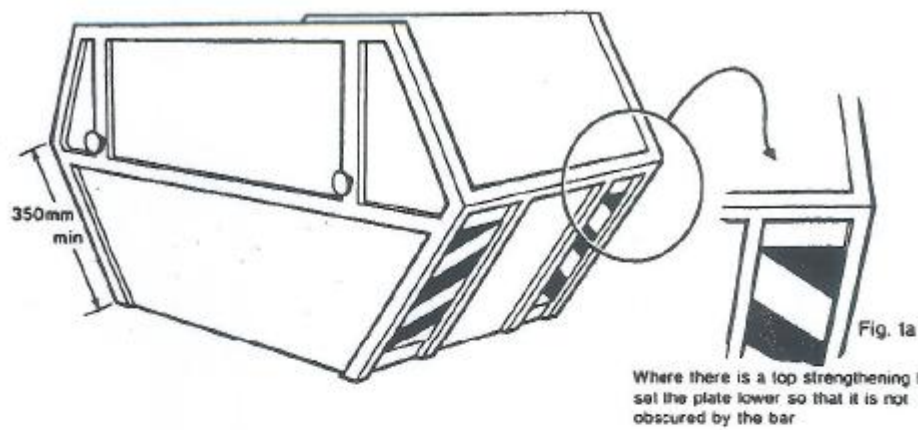

Fig. 1 Skip with equal sized low ends.

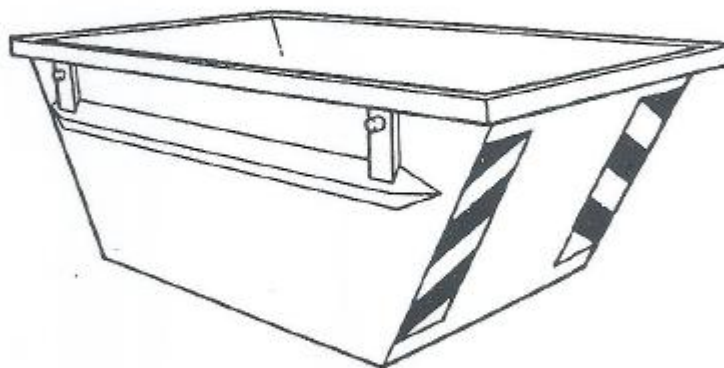

Fig. 2 Mini-Skip.

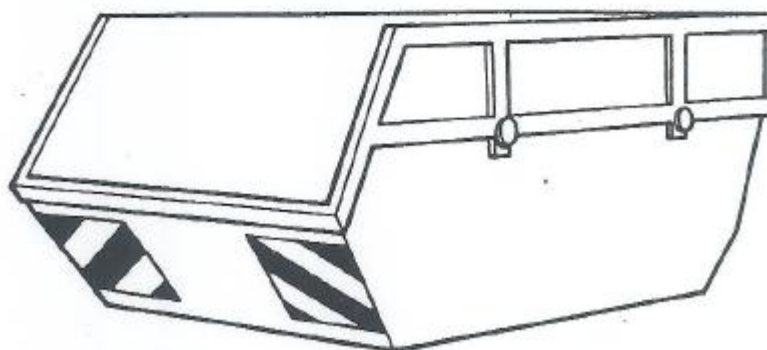

Fig. 3 Skip with different sized ends; one very low.

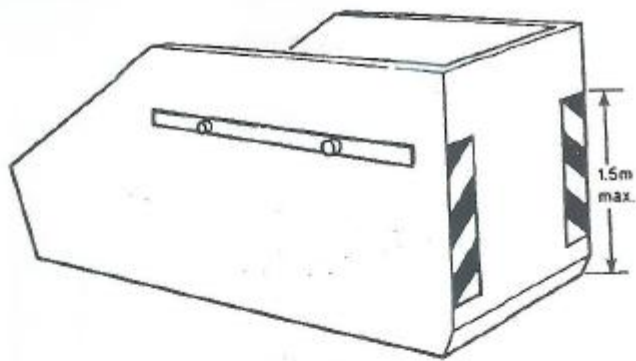

Fig. 4 Skip with high end.

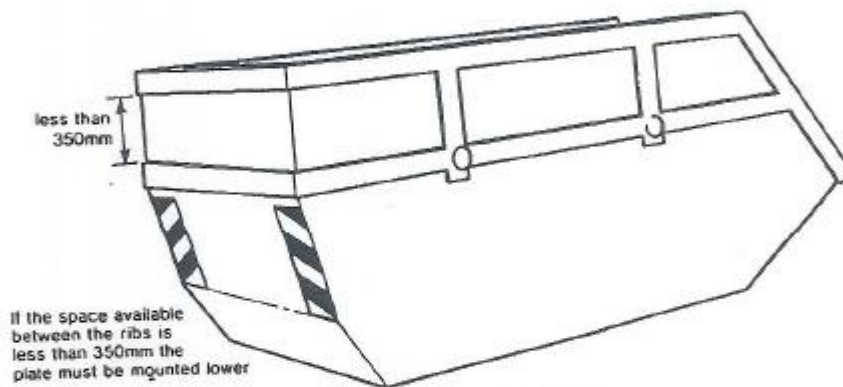

Fig. 5 Skip with angled end.

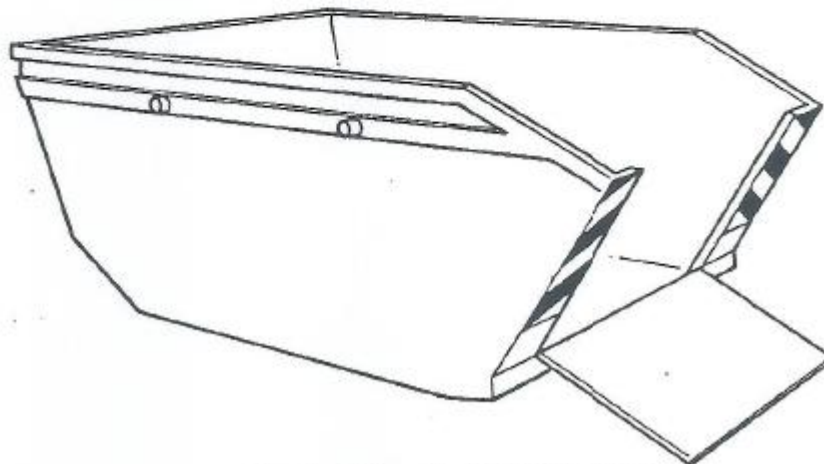

Fig. 6 Skip with drop end door.

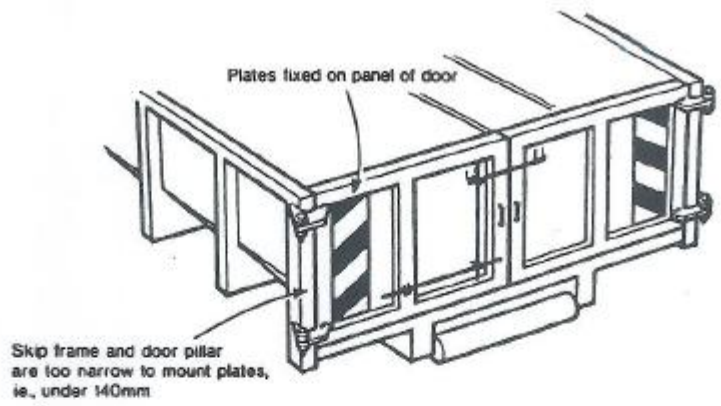

Fig. 7 Demountable body with opening end doors.

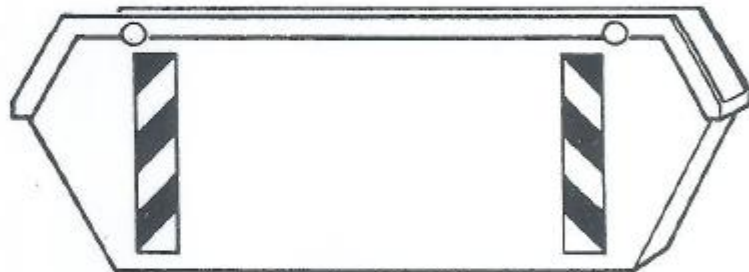

Fig. 8 Skip placed sideways on the road.

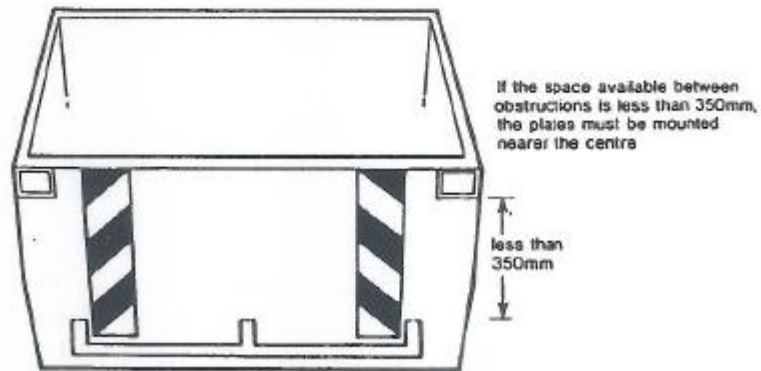
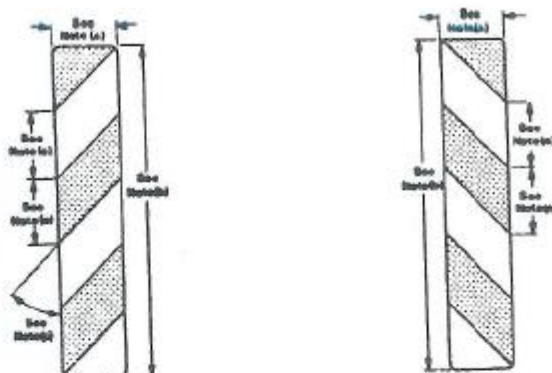

Fig. 9 Skip end with lamp housings and other structural obstructions.

Specifications about design



Notes:

- (a) The width of each half of the marking shall be not less than 140 millimetres nor more than 280 millimetres.
- (b) The length of each half of the marking shall be not less than 350 millimetres nor more than 700 millimetres.
- (c) The angle of each stripe shall be not less than 40 degrees to the vertical nor more than 50 degrees to the vertical.
- (d) Each half of the marking shall have a minimum area of 980 square centimetres.
- (e) The breadth of each stripe shall be not less than 133 millimetres nor more than 147 millimetres.

Requirements as to markings

1. The marking specified in Schedule 1 shall consist of two plates of equal size and the same shape as one another.
2. Each such plate shall comply with the requirements specified in the British Standard Specification for Rear Marking Plates for Vehicles issued by the British Standards Institution and published on 1st April 1970 under number BS AU 152: 1970 and shall be marked as provided in paragraph 5 of that Standard.
3. The two plates comprising the marking shall be securely attached to the end of the builder's skip in such a manner that—
 - (a) each plate is as near to an outer edge of the skip as the construction of the skip allows, so, however, that no part of any plate projects beyond an outer edge of the end of the skip;
 - (b) the innermost edge of each plate is parallel to and the same distance from the vertical plane passing through the longitudinal axis of the skip;
 - (c) the upper edge of each plate is parallel to and the same distance from the upper edge of the end of the skip;
 - (d) no part of either plate is attached to—
 - (i) any lid, or
 - (ii) any door except in a case where a door is the only place to which the plate can possibly or conveniently be fixed; and
 - (e) the upper edge of each plate is—
 - (i) not more than 1.5 metres from the ground, and
 - (ii) not lower than the upper edge of the skip save in so far as this may be necessary on account of the construction of the skip, the provisions of Regulation 4 or the provisions of sub-paragraph (i) above.
4. The stippled areas in the diagram in Schedule 1 shall be of red fluorescent material, and the unstippled areas in that diagram shall be of yellow reflex material.